

RF & MICROWAVE TRANSISTORS TELEMETRY APPLICATIONS

- REFRACTORY/GOLD METALLIZATION
- EMITTER SITE BALLASTED
- ∞ :1 VSWR CAPABILITY AT RATED CONDITIONS
- LOW THERMAL RESISTANCE
- INPUT/OUTPUT MATCHING
- OVERLAY GEOMETRY
- METAL/CERAMIC HERMETIC PACKAGE
- $P_{OUT} = 9$ W MIN. WITH 6.5 dB GAIN

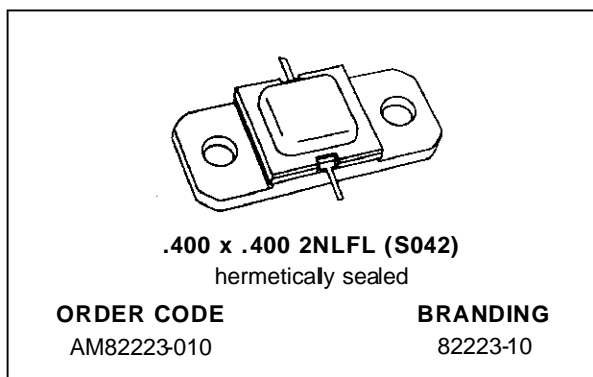

DESCRIPTION

The AM82223-010 is a common base, silicon NPN bipolar transistor designed for high gain and efficiency in the 2.2 – 2.3 GHz frequency range.

Suitable for hi-rel aerospace telemetry applications, the AM82223-010 is provided in the industry-standard AMPAC™ metal/ceramic hermetic package and incorporates internal input and output impedance matching structures along with a rugged, emitter-site ballasted overlay die geometry.

AM82223-010 is capable of withstanding ∞ :1 load mismatch at any phase angle under full rated operating conditions.

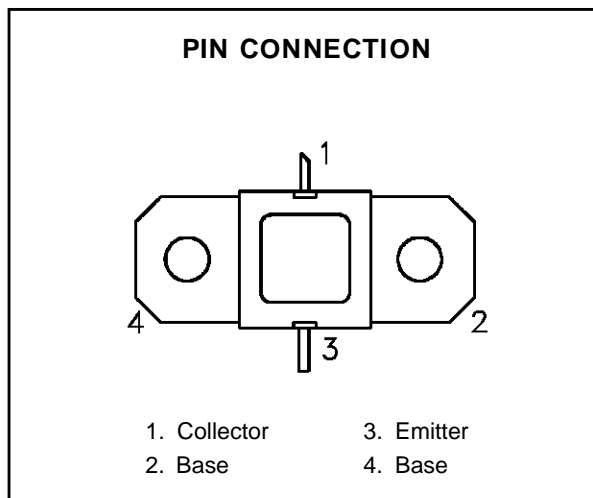

ABSOLUTE MAXIMUM RATINGS ($T_{case} = 25^{\circ}C$)

Symbol	Parameter	Value	Unit
P_{DISS}	Power Dissipation* ($T_C \leq 75^{\circ}C$)	28	W
I_C	Device Current*	1.2	A
V_{CC}	Collector-Supply Voltage*	26	V
T_J	Junction Temperature	200	$^{\circ}C$
T_{STG}	Storage Temperature	- 65 to +200	$^{\circ}C$

THERMAL DATA

$R_{TH(j-c)}$	Junction-Case Thermal Resistance	4.4	$^{\circ}C/W$
---------------	----------------------------------	-----	---------------

*Applies only to rated RF amplifier operation

NOTE: Thermal Resistance determined by Infra-Red Scanning of Hot-Spot Junction Temperature at rated RF operating conditions.

ELECTRICAL SPECIFICATIONS ($T_{\text{case}} = 25^{\circ}\text{C}$)

STATIC

Symbol	Test Conditions			Value			Unit
				Min.	Typ.	Max.	
BV_{CBO}	$I_{\text{C}} = 5 \text{ mA}$	$I_{\text{E}} = 0 \text{ mA}$	45	—	—	V	
BV_{CER}	$I_{\text{C}} = 10 \text{ mA}$	$R_{\text{BE}} = 10 \Omega$	45	—	—	V	
BV_{EBO}	$I_{\text{E}} = 1 \text{ mA}$	$I_{\text{C}} = 0 \text{ mA}$	3.5	—	—	V	
I_{CBO}	$V_{\text{CB}} = 24 \text{ V}$		—	—	1	mA	
h_{FE}	$V_{\text{CE}} = 5 \text{ V}$	$I_{\text{C}} = 750 \text{ mA}$	20	—	300	—	

DYNAMIC

Symbol	Test Conditions			Value			Unit
				Min.	Typ.	Max.	
P_{OUT}	$f = 2.2 - 2.3 \text{ GHz}$	$P_{\text{IN}} = 2.0 \text{ W}$	$V_{\text{CC}} = 24 \text{ V}$	9.0	—	—	W
η_{c}	$f = 2.2 - 2.3 \text{ GHz}$	$P_{\text{IN}} = 2.0 \text{ W}$	$V_{\text{CC}} = 24 \text{ V}$	40	—	—	%
P_{G}	$f = 2.2 - 2.3 \text{ GHz}$	$P_{\text{IN}} = 2.0 \text{ W}$	$V_{\text{CC}} = 24 \text{ V}$	6.5	—	—	dB

PACKAGE MECHANICAL DATA

Ref.: Dwg. No. 12-0213 rev. A

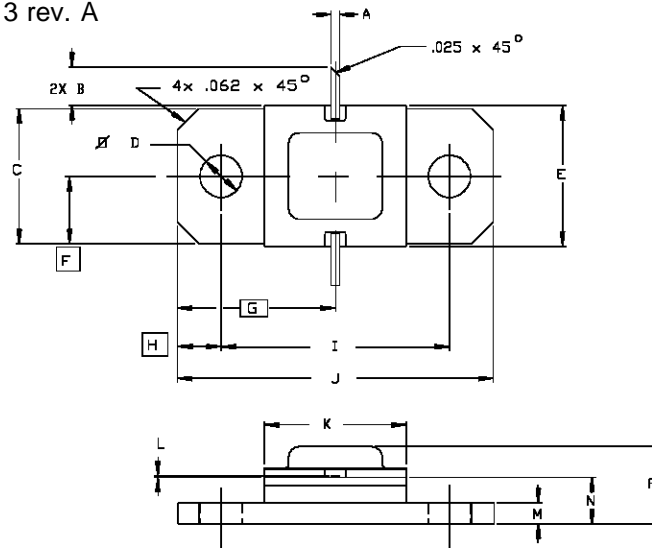

SGS-THOMSON MICROELECTRONICS		CONT'D			
	MINIMUM Inches/mm	MAXIMUM Inches/mm		MINIMUM Inches/mm	MAXIMUM Inches/mm
A	.020/0,51	.030/0,76	K	.395/10,03	.415/10,54
B	.100/2,54		L	.004/0,10	.006/0,18
C	.376/9,55	.396/10,06	M	.052/1,32	.072/1,83
D	.110/2,79	.130/3,30	N	.118/3,00	.131/3,33
E	.395/10,03	.407/10,34	P		.230/5,84
F	.193/4,90				
G	.450/11,43				
H	.125/3,18				
I	.540/16,25	.560/16,76			
J	.890/22,61	.910/23,11			

Information furnished is believed to be accurate and reliable. However, SGS-THOMSON Microelectronics assumes no responsibility for the consequences of use of such information nor for any infringement of patents or other rights of third parties which may result from its use. No license is granted by implication or otherwise under any patent or patent rights of SGS-THOMSON Microelectronics. Specifications mentioned in this publication are subject to change without notice. This publication supersedes and replaces all information previously supplied. SGS-THOMSON Microelectronics products are not authorized for use as critical components in life support devices or systems without express written approval of SGS-THOMSON Microelectronics.

©1994 SGS-THOMSON Microelectronics - All Rights Reserved

SGS-THOMSON Microelectronics GROUP OF COMPANIES

Australia - Brazil - France - Germany - Hong Kong - Italy - Japan - Korea - Malaysia - Malta - Morocco - The Netherlands - Singapore - Spain - Sweden - Switzerland - Taiwan - Thailand - United Kingdom - U.S.A.